

UNTHA

shredding technology

The reliable brand!

RS30

RS40



RS30/RS40

A TRADITION OF RELIABILITY

The reliable and rugged RS30 and RS40 shredders are often used for processing long solid wooden parts and have a proven track record for decades. These compact machines can stand alone or be integrated into comprehensive systems.

High availability and consistent throughput are hallmarks of these tough and dependable machines.

The homogeneous final product is perfectly suited for heat recovery and the production of wood briquettes.

TYPICAL APPLICATIONS

▪ Solid wood (long wooden parts, chips) ▪ Veneer ▪ Card-board / paper (mixed with wood) ▪ Bark ▪ etc..

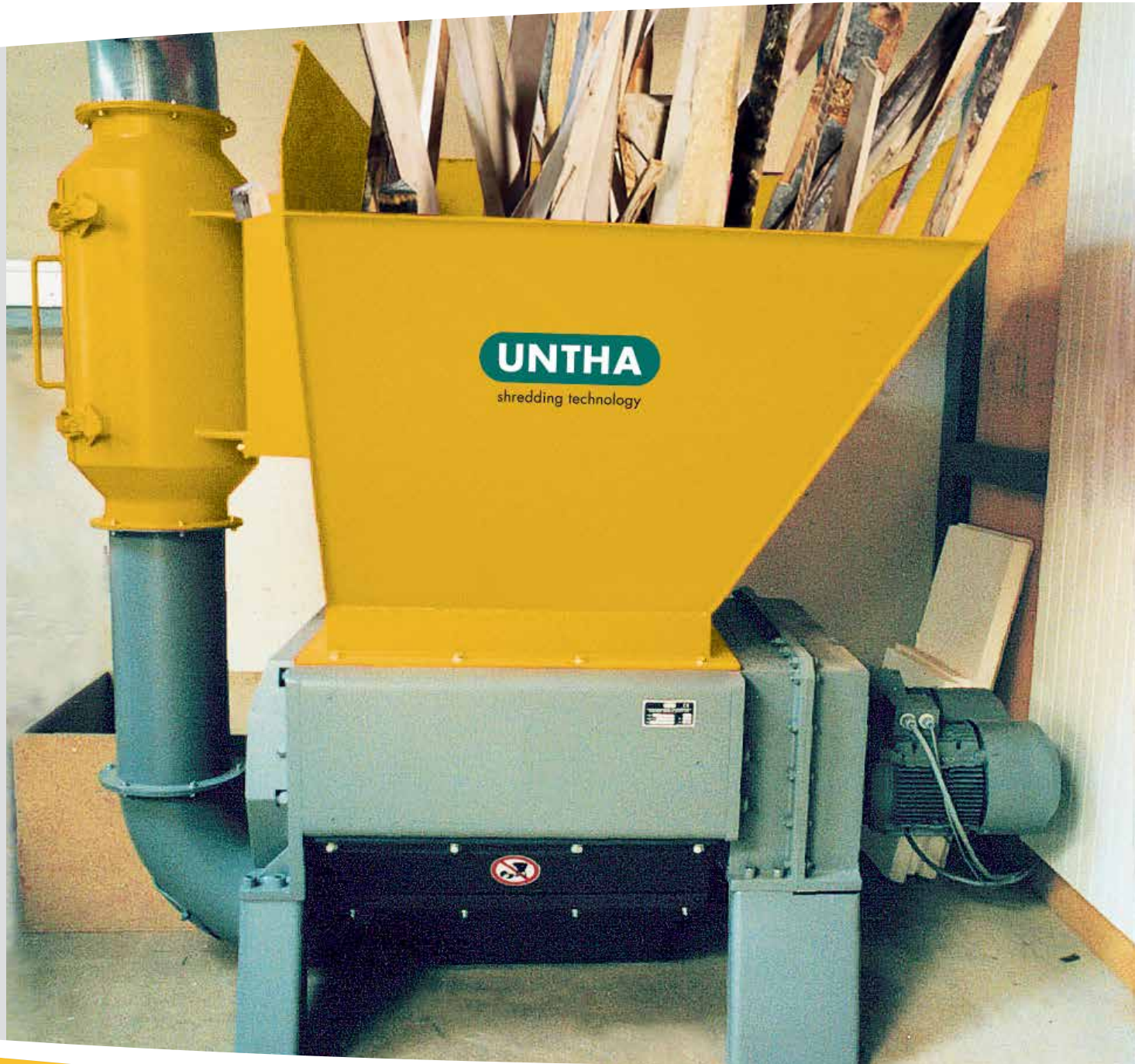

RS30/RS40

4-shaft cutting system

TECHNICAL DATA		RS30	RS40 / 22 kW	RS40 / 30-37 kW
Power	kW	2 x 5.5/2 x 7.5/2 x 11	2 x 11	2 x 15/2 x 18.5
Charging hole	mm	450 x 560	450/750 x 700	480/750/960 x 700
No. of indexable inserts	units	4	4	4
Rotor speed main shaft	rpm	appr. 23	appr. 20	appr. 23
Rotor speed secondary shaft	rpm	appr. 34	appr. 28	appr. 34
Perforated screen Ø	mm	15 - 40	15 - 40	15 - 40
Weight	kg	appr. 1,100	appr. 1,400/1,700	appr. 1,700/2,100/2,400
Noise level pressure LPA1m	dB (A)	appr. 80	appr. 80	appr. 80
Throughput*				
- Screen Ø 15 - 25 mm	kg/h			
- Screen Ø 30 - 40 mm	kg/h	300 - 700	400 - 1,100	500 - 1,400
		800 - 1,200	800 - 1,500	1,100 - 2,000

*) depending on: quality of material and diameter of perforated screen

TYPE/ DIMENSIONS	SB	L	H	H1	H2	W	D	D1	D2
RS30/2 x 5.5 kW	450	1,250	1,900	820	450	1,000	1,280	560	1,090
RS30/2 x 7.5 kW	450	1,300	1,900	820	450	1,000	1,280	560	1,090
RS30/2 x 11 kW	450	1,340	1,900	820	450	1,000	1,280	560	1,090
RS40/22 kW	450	1,360	1,970	820	450	1,000	1,370	700	1,190
RS40/22 kW	750	1,660	1,970	820	450	1,300	1,370	700	1,190
RS40/30 - 37 kW	480	1,530	1,990	880	500	1,045	1,415	700	1,190
RS40/30 - 37 kW	750	1,800	1,990	880	500	1,315	1,415	700	1,190
RS40/30 - 37 kW	960	2,010	1,990	880	500	1,525	1,415	700	1,190

All dimensions in mm. SB= Cutting system width

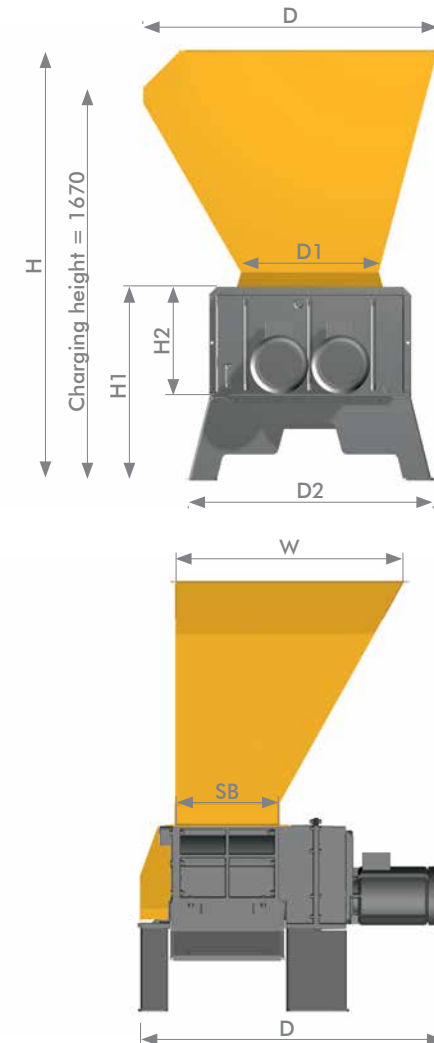

**40 years of expertise.
More than 9,000 shredders
in daily operation!**

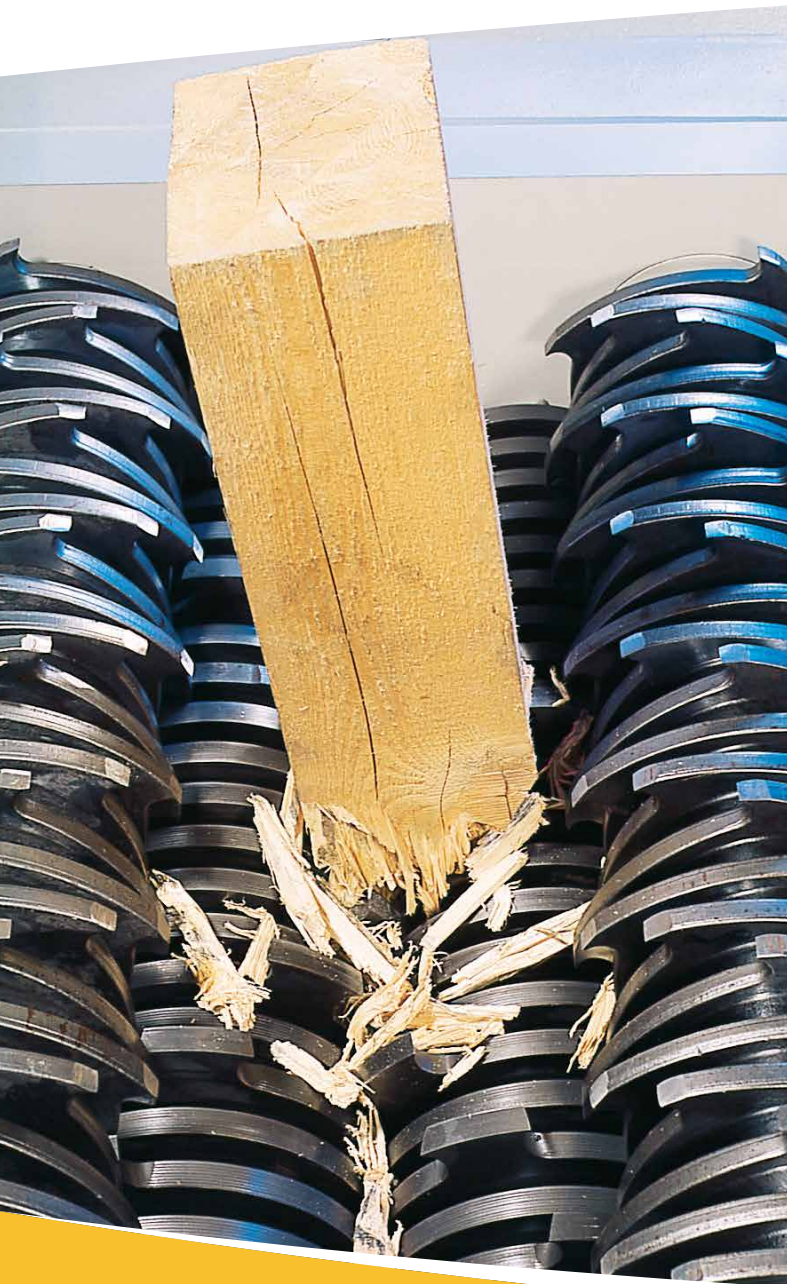

QUALITY FEATURES

High availability

- > highest quality standards in production
- > rugged cast frame design
- > high-quality bearings with an extremely long service life
- > high resistance to foreign material thanks to low-speed cutting shafts
- > straight forward design (couplings etc.) ensures reliable operation
- > heavy-duty cutting disks with integral collars which distribute cutting forces over a wide area
- > die-forged and case-hardened cutting disks
- > reliable drive with two independent motors and heavy-duty gears
- > one-step shredding concept (pre- and post-shredding in a single pass)
- > automatic material in-feed which makes ram systems superfluous

Unrivalled in throughput

- > high throughput thanks to very large screen surface and tailored cutter design
- > high torques thanks to slowly rotating cutting shafts
- > little downtime

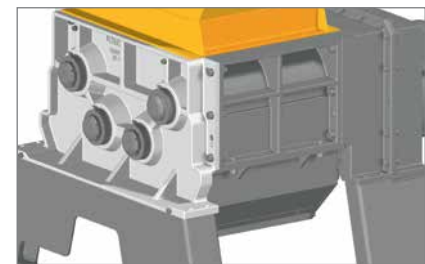
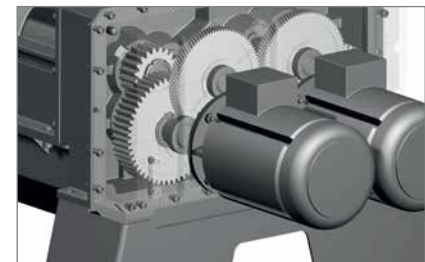
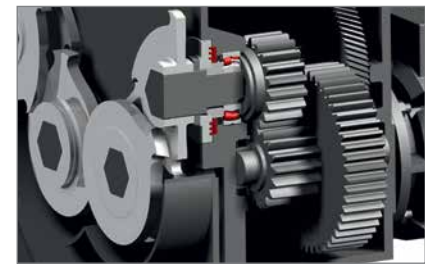



*) or 2,000 h, whichever value occurs first

Low noise and dust development

- > slow rotation of cutting shafts

Sophisticated control concept

- > automatic foreign material detection and stop
- > automatic reverse function to prevent motor overloading
- > automatic shutoff when idling
- > user-friendly operating panel on the control cabinet

Options

- > suction hood (suction from all four sides possible)
- > customer-specific feed hopper
- > customer-specific cutting disks tailored to individual requirements
- > customer-specific base frames
- > pipe magnets
- > belt conveyors with magnetic separation

UNTHA CUSTOMER SERVICE – AS RELIABLE AS OUR PRODUCTS

Our customers' satisfaction is our number one priority. Our experienced Customer Service experts make sure the machines and plants supplied by us are maintained and optimized to increase their service life and ensure efficient and profitable operation.

For more information please refer to our Customer Service brochure.

HOW UNTHA CUSTOMER SERVICE CAN BENEFIT YOU

Cutting systems overhaul

- > the low-cost alternative to buying new cutting systems
- > extension of service life and increase in productivity of used cutting systems
- > optimisation of worn cutting systems

Spare parts

- > original UNTHA replacement parts for maximum availability of your machine and plant
- > comprehensive spare parts stock of more than 10,000 items
- > replacement parts are provided within two working days thanks to our advanced logistics concept¹⁾
- > all original UNTHA replacement parts are "made in Austria"

Repair

- > short response time and expert support in emergencies
- > service hotline
- > highly qualified and experienced service engineers
- > general overhauls on site and at the UNTHA Service Centre

Preventive maintenance and maintenance agreements

- > UNTHA quality maintenance programmes ensure high up-time of machines
- > regular UNTHA quality maintenance ensures high performance of the machine
- > clear reduction in operating and maintenance costs
- > modular UNTHA quality Maintenance Agreements available

Training

- > expert training courses for optimum operation and maintenance of machines
- > hands-on and multimedia courses for immediate, positive training results
- > individual training courses and on-site advice available

Diagnosis of machine problems

- > prevention of serious damage
- > evaluation by means of state-of-the-art diagnostic equipment
- > remote diagnosis via GSM modem for swift troubleshooting

¹⁾ applies to all articles in stock





OUR MISSION

We have been a reliable and expert partner in the shredding industry for more than 40 years. Based on the latest technologies and with the help of our highly qualified staff, we develop and produce innovative and tailored shredding solutions for all applications.

Our every thought and action revolve around our customers and markets. We provide outstanding products and services of the highest quality and reliability and are therefore able to strengthen our customers' market position.

For us, reliability, credibility and a sound approach to business in both practice and theory are the central values that make our success in international markets possible. These values increase our competitiveness and help us to focus on our core competences and on the ongoing improvement of our business processes. The prerequisites for our success are innovative strength, problem-solving skills and our distinctive quality thinking.

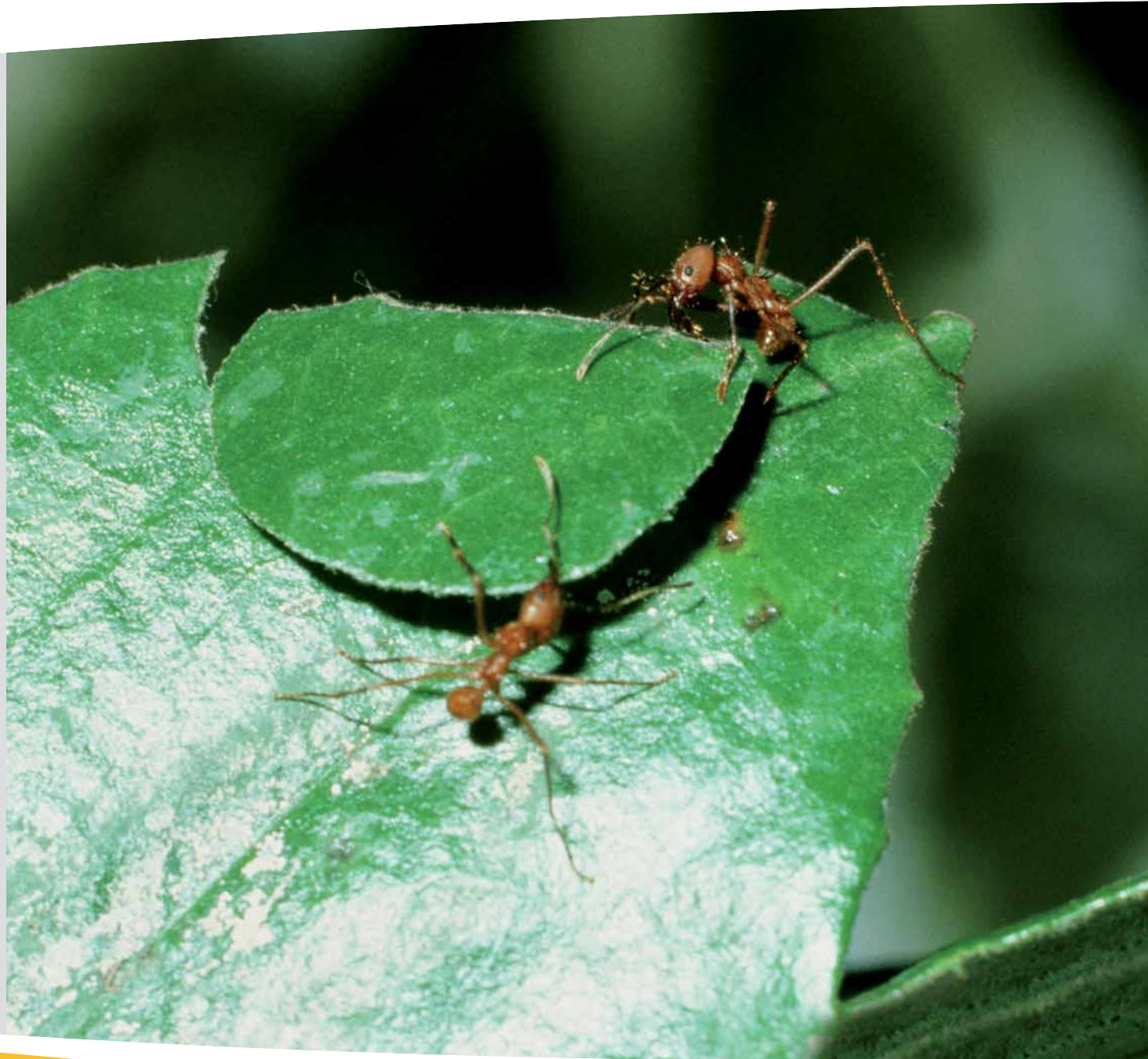

THE FACTS SPEAK IN OUR FAVOUR

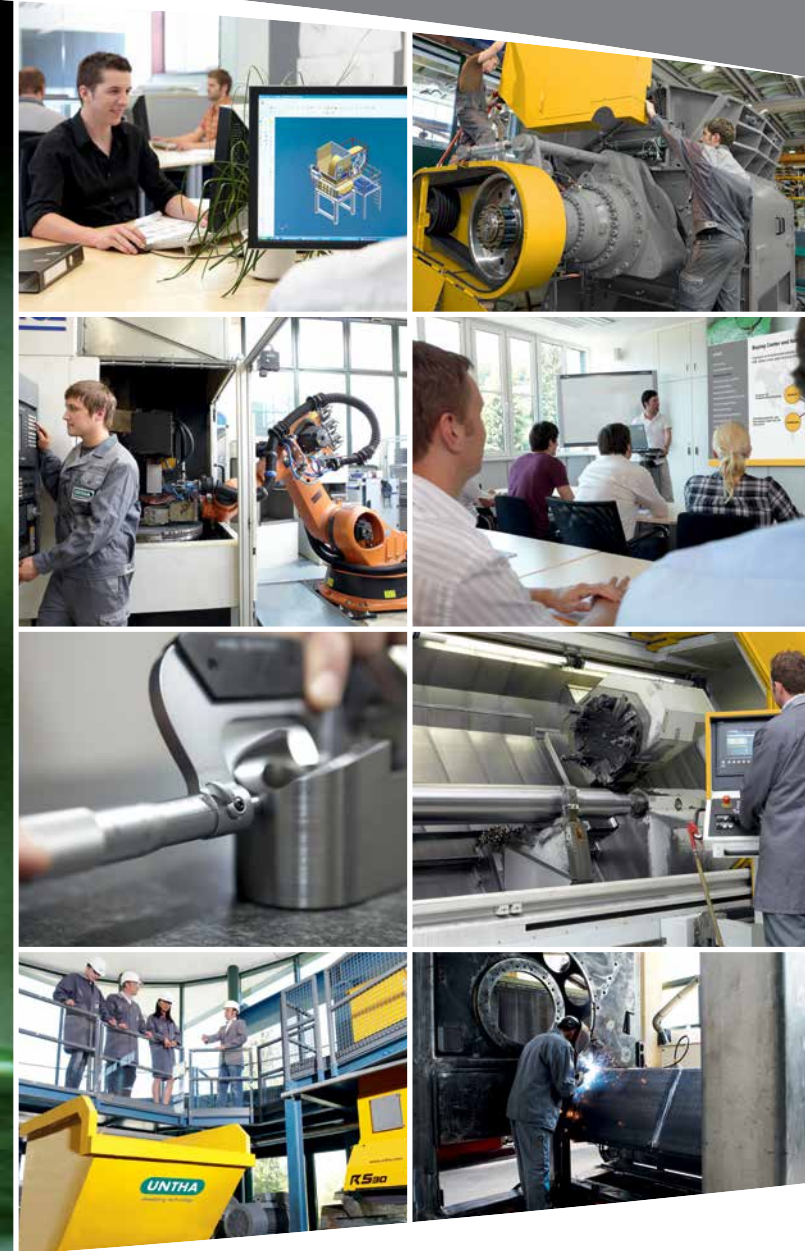



shredding technology

The reliable brand!



UNTHA shredding technology

Kellau 141
A-5431 Kuchl / Salzburg, Austria
Tel +43 6244 7016 0
Fax +43 6244 7016 1
info@untha.com
www.untha.com



Authorised partner of UNTHA

